

Features

- Easy mounting on wall, DIN rail or panel
- 2 pressure ranges (Pa and in H₂O)
- Accessible zero and span adjustment potentiometers
- ¼" brass tubing connections
- LED status indicator
- Specially designed for critical and regulated environments
- Euro style detachable connector
- NIST traceable (certificate included)

Vaisala Differential Pressure Transmitter PDT101 offers precise measurement and control of very low pressures.

Operating Environment

PDT101 is designed especially for demanding life science and high technology cleanroom applications. The transmitter is ideal for incorporating into the Vaisala Veriteq Continuous Monitoring System to measure and monitor the critical environmental parameters as required in regulated environments.

Performance

PDT101 offers high accuracy, sensitivity and stability with accuracy 0.40 % of span providing a highly reliable and repeatable measurement. The sensor

uses a micro-machined, ultra-thin silicon diaphragm which provides inherent sensor repeatability and stability. The sensor enables precise measurement and control in high performance cleanrooms. The PDT101 transmitter is available with voltage output (3-wire) or current output (2-wire).

Zero and span adjustment screws are available on every PDT101 model. Both adjustments are accessible from the front of the unit.

Applications

PDT101 is suitable for high performance cleanroom environments in the life science, semiconductor and electronics industries. As part of a continuous monitoring system, it is highly suitable for regulated environments where continuous, documented and redundant data is a requirement to meet FDA regulations. The compact design is well suited for mounting in a cleanroom or in the adjacent corridor with LED indicator lights for quick and easy power status spot check.

Technical Data

Measurement performance

Measurement ranges (bidirectional)	±60 Pa ±0.25 in H ₂ O
Accuracy (incl. non-linearity, hysteresis, repeatability and zero/span calibration settings)	0.4 % span
Long-term stability	≤ 0.5 % span/year
Response time (10 ... 90 %)	250 ms
Warm-up time	15 s
Compensated temperature range	+2 ... +54 °C (+35.6 ... +129.2 °F)
Temperature dependence	±(0.065 Pa + 0.054 % of reading) / °C or ±(0.00015 in H ₂ O + 0.03 % of reading) / °F (reference 21 °C or 70 °F)
Pressure type	Differential, gauge, vacuum and compound

Overpressure

Proof pressure	1.0 bar
Burst pressure	1.7 bar
Static pressure	1.7 bar

Mounting position

Error (zero adjustable)	≤ 1 %/g (calibration in vertical position is standard)
-------------------------	--

Adjustments (front accessible)

Zero	±5 % span
Span	±3 % span

Operating environment

Operating temperature	-18 ... +70 °C (-0.4 ... +158 °F)
Storage temperature	-40 ... +82 °C (-40 ... +179.6 °F)
EMC compliance	EN 61326-1, Basic immunity test requirements

Note: If used in an electromagnetic field of 3 V/m, with narrow frequency area of 80 ... 120 Mhz, it is possible that the current output of PDT101 can deviate max. 0.8 % (with accuracyspecified 0.4 %)

Mechanical specifications

Medium (measured gas)	Clean and dry air, non-conducting and non-corrosive gases
Mounting	Threaded fastener for wall mounting or DIN rail type EN50022
IP rating	IP40
Weight	0.07 kg
Material	
Process connection	Brass
Sensor element	Silicon, aluminium, glass
Case	NEMA type 1 fire-retardant ABS 1 (meets UL94-5VA)

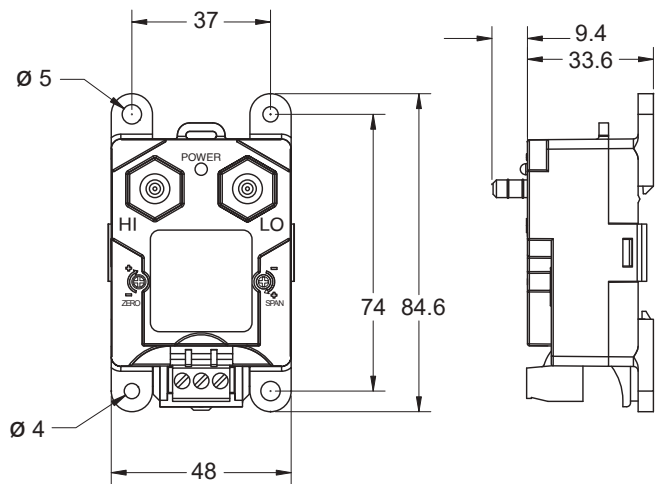

Dimensions in mm

Inputs and outputs

Process connection	1/4" barbed fittings
Max. loop resistance for 4 ... 20 mA	≤ (Supply voltage - 12 V)/0.022 A
Supply current	Max. 20 mA for 4 ... 20 mA output signal
Optical process diagnostics	LED visual indicator
Electrical connection	Euro style pluggable terminal block accepts 12 ... 26 AWG wire (0.13 up to 3.31 mm ²)
Output signal	
2-wire	4 ... 20 mA
3-wire	0 ... 5 VDC (user selectable 0 ... 10 VDC)
Operating voltage	
2-wire output 4 ... 20 mA	12 ... 36 VDC
3-wire output 0 ... 5 VDC	11.5 ... 36 VDC
3-wire output 0 ... 10 VDC	14 ... 36 VDC or 24 VAC

Order information for PDT101

