

Chroma-FP-OD Commercial Freeze Protection Controller

- Automatic Control for Heat Tracing and Freeze Protection
- NEMA 4X Outdoor Rated to -40°F
- Integrated Electronic Controller with Backlit LCD Display
- Adjustable Temperature Set-point 45°F to -7°F
- User Friendly Interface
- Multiple Sensors Input – Optional
- Up to 4 Temperature/Moisture Sensors
- Output Relay 30A @ 120/208/240 VAC
- 30mA Fixed, Integral Ground Fault Circuit Breaker
- Adjustable Hold-On Time Delay Range: 0-99 Hours
- Three Modes of Operation
 - Automatic
 - Manual (ON/OFF)
 - Commissioning
- Includes 30ft Termistor
- Technician/Commissioning Mode for Easy and Fast System Testing Year Round
- cULus Rated
- ETL Certification (US & Canada)
- ROHS Compliant



Intertek



Description

The Chroma-FP-OD series of controls is a "Plug and Play" controller for freeze protection applications. When the temperature drops below the adjustable set-point, it activates the contactor energizing the heating elements.

The Technician mode allows installers or technicians to adjust the parameters for customized installations using the electronic controller installed in the front panel.

The Chroma-FP-OD Built-in Ground Fault interrupter allows manual reset from the front panel. Three LEDs visible through the transparent plastic cover provides information about the status of the system.

Chroma-FP Models

- Chroma-FP1-OD – Power box with 1 contactor (30A) & 120V output to heaters
- Chroma-FP2-OD – Power box with 1 contactor (30A) & 208/240V output to heaters

Specifications

Outdoor Ambient Operating Temperature.....	-40°F to 122°F (-40° C to 50°C)
Power Switching.....	30A EMR
Number of Circuits	1
Input Voltage.....	120VAC, 208-240VAC
Heater Voltage.....	120VAC, 208-240VAC
Communications.....	Dry Contact Alarm Relay (NO/NC)
Adjustable Parameters	Set-Point, Upper and Lower Limit Temperature
Enclosure Ratings.....	NEMA 4X/IP67

COMMERCIAL HEAT TRACE

Chroma-FP-OD Commercial Freeze Protection Controller (cont'd.)

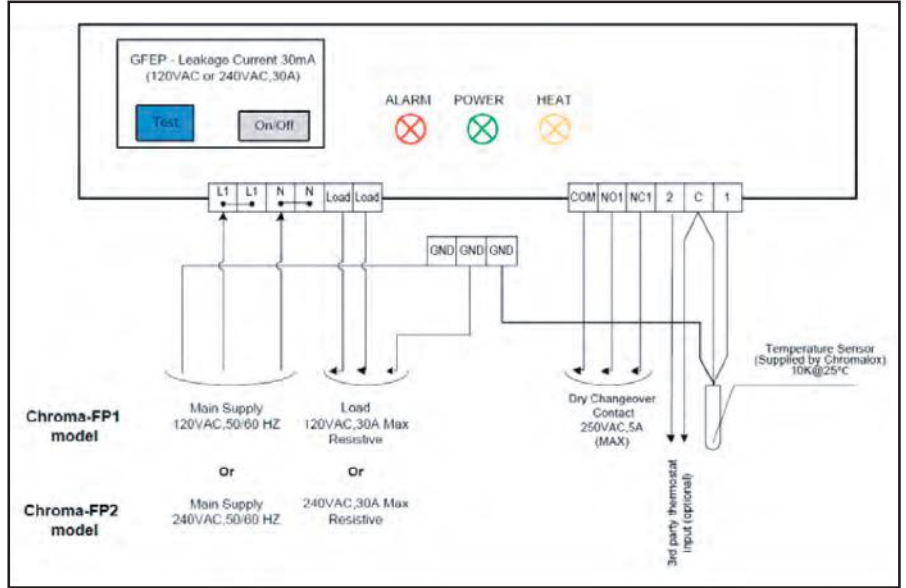

Front View

Dimensions

Model	Units	H	W	D
Chroma-FP1-OD	Inch	12	8	5
	cm	300	200	130
Chroma-FP2-OD	Inch	12	8	5
	cm	300	200	130



Side View

Accessories

Model	Description	Max. Total Amperage	Max. Voltage	PCN
Chroma-FP1-OD	Freeze Protection Controller, 1 Contactor (1-2P @30A), 120V	30A	120V	515119
Chroma-FP2-OD	Freeze Protection Controller, 1 Contactor (1-2P @30A), 208/240V	30A	240V	515127