



VDG series is widely used for measuring the fans or blowers pressure, filter resistant, wind speed, furnace gas pressure, Orifice pressure difference, bubble level and hydraulic system pressure. It is also applied to regulate the air-gas combustion ratio and automatic valve or detecting the breathing, and blood pressure in medical equipment. There are some more applications like micro- electronics, aviation and space, environmental protection project, biological, HVAC, food and beverage and precision electronic processing.

FEATURES

- Magnetic link drive mechanism eliminates friction caused by gear drive fundamentally
- No necessity to fill with liquid
- Motion of the pointer without inertia or drift
- No hysteresis
- Excellent anti-vibration and anti-shaking performance
- Positive, negative or differential pressure can be measured multiple ranges are optional, minimum 0 ~ 30Pa to maximum 0 ~ 10KPa
- 2 sets of pressure ports (side, back) + 3 mounting modes = free and flexible application
- Excellent accuracy, reasonable price

SPECIFICATION

Model	VDG
Measuring Range	0-30Pa, -30-30Pa, 0-60Pa, -60-60Pa, 0-125Pa, -125-125Pa, 0-250Pa, -250-250Pa, 0-300Pa, 0-500Pa, 0-750Pa, 0-1KPa, 0-2KPa, 0-3KPa, 0-4KPa, 0-5KPa, 0-6KPa, 0-7KPa, 0-8KPa, 0-9KPa, 0-10KPa
Accuracy	±2% FS under 21°C (125Pa, 3%; 4% is 60Pa)
Over load	Around 172KPa, the rubber plug for overpressure will be flush away
Rated pressure	-68~103KPa
Environment Temperature	-7°C~80°C

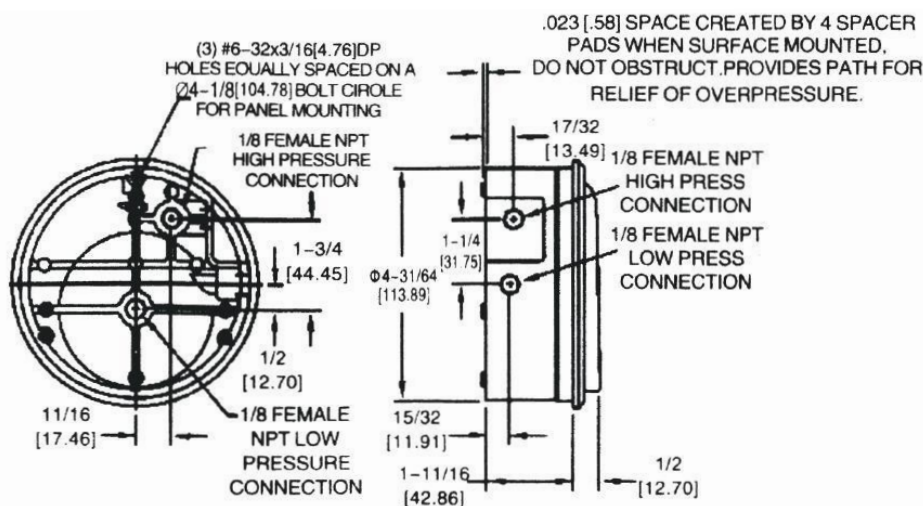

Dimension in mm:

