



MGP261 Multigas Probe

For methane, carbon dioxide, and humidity measurement



Features

- Compact in situ probe with CH₄, CO₂, and H₂O vapor measurement
- Superior long-term stability and repeatability with proprietary infrared technology — no calibration gases needed
- Direct installation into process: no sample treatment needed
- Certified for Ex Zone 0/1
- Probe heating eliminates condensation in wet processes
- Corrosion-resistant stainless steel housing (IP66)
- Standalone probe with digital Modbus RTU over RS-485 or 3 analog outputs (4 ... 20 mA)
- Compatible with Vaisala Insight PC software

Vaisala CARBOCAP® MGP261 Multigas Probe for Methane, Carbon Dioxide, and Humidity Measurement is designed for in situ measurements in demanding biogas processing conditions where repeatable, stable, and accurate measurement is essential. MGP261 is Ex certified for use in Ex Zone 0 (parts inserted into process) and Ex Zone 1 (parts outside the process).

Up to three measurements in one compact unit

MGP261 measures the main components of biogas and landfill gas: methane (CH₄), carbon dioxide (CO₂), and humidity. These gases make up the bulk of biogas, and measuring all three parameters gives you a 100% picture of the process. MGP261 measures CH₄, CO₂, and humidity in vol-% units, or alternatively dewpoint temperature (T_d) in °C.

Methane measurement for biogas quality and process control

Methane concentration measurement tells you the calorific value of the gas produced in real time. With internal temperature measurement for

compensation purposes and an option for external pressure or temperature compensation input, the patented CARBOCAP® measurement gives unparalleled stability and reliability without calibration gases. Application areas include anaerobic digestion and landfill gas monitoring, activated carbon filter monitoring in biogas treatment process, and CHP engine feed gas monitoring.

Direct in situ measurement without sample treatment

MGP261 measures gases directly in the process pipeline without a need for moisture removal. This simplifies the measurement both in situ and as part of an extractive system with optional flow through cell accessory. The heated

optical elements provide reliable measurements even in most demanding process conditions with condensate in the process gas.

Robust, weatherproof, and Ex certified for zones 0 and 1

MGP261 is Ex certified for use in Ex Zone 0 (parts inserted into process) and Ex Zone 1 (parts outside the process). The electronics and optics of the IP66-rated instrument are protected by encapsulation in a potting compound to ensure maximum resistance to weather, dust, and ingress of process gases in the probe. Materials exposed to process gas are carefully selected for good chemical resistance against hydrogen sulfide: they include stainless 316L steel and polytetrafluoroethylene (PTFE).

Technical data

Measurement performance

| Property | Methane CH ₄ | Carbon dioxide CO ₂ | Water vapor H ₂ O |
|-------------------|-------------------------|--------------------------------|---|
| Sensor | CARBOCAP® | CARBOCAP® | CARBOCAP® |
| Measurement unit | Volume-% | Volume-% | Volume-%, dew point °C |
| Measurement range | 0 ... 100 vol-% | 0 ... 100 vol-% | 0 ... 25 vol-%, -10 ... +60 °C (14 ... +140 °F) |

Accuracy specification at 25 °C (+77 °F) and 1013 mbar including non-linearity, calibration uncertainty, and repeatability; temperature and pressure compensated

| | | | |
|---|--|--|---|
| Accuracy at +25 °C (+77 °F) and 1013 mbar ¹⁾ | <ul style="list-style-type: none"> 0 ... 40 vol-%: ±2 vol-% 40 ... 70 vol-%: ±1 vol-% 70 ... 100 vol-%: ±2 vol-% | <ul style="list-style-type: none"> 0 ... 30 vol-%: ±2 vol-% 30 ... 50 vol-%: ±1 vol-% 50 ... 100 vol-%: ±2 vol-% | <ul style="list-style-type: none"> 0 ... 25 vol-%: ±0.5 vol-% |
|---|--|--|---|

| | | | |
|---------------|------------------------|------------------------|------------------------|
| Repeatability | ±0.5 vol-% at 60 vol-% | ±0.3 vol-% at 40 vol-% | ±0.1 vol-% at 10 vol-% |
|---------------|------------------------|------------------------|------------------------|

| | | | |
|------------------------|--|--|---|
| Temperature dependence | Compensated, 0 ... 100 vol-%: ±0.1 % of reading/°C | Compensated, 0 ... 100 vol-%: ±0.1 % of reading/°C | Compensated, 0 ... 25 vol-%: ±0.1 % of reading/°C |
| | Uncompensated, 0 ... 100 vol-%: -0.9 % of reading/°C | Uncompensated, 0 ... 100 vol-%: -0.9 % of reading/°C | Uncompensated, 0 ... 25 vol-%: -0.4 % of reading/°C |

| | | | |
|---------------------|--|--|---|
| Pressure dependence | Compensated, 0 ... 100 vol-%: ±0.015 % of reading/mbar | Compensated, 0 ... 100 vol-%: ±0.01 % of reading/mbar | Compensated, 0 ... 25 vol-%: ±0.06 % of reading/mbar |
| | Uncompensated, 0 ... 100 vol-%: +0.2 % of reading/mbar | Uncompensated, 0 ... 100 vol-%: +0.2 % of reading/mbar | Uncompensated, 0 ... 25 vol-%: +0.2 % of reading/mbar |

| | | | |
|---------------------|---------------|---------------|---------------|
| Long-term stability | ±2 vol-%/year | ±2 vol-%/year | ±2 vol-%/year |
|---------------------|---------------|---------------|---------------|

| | |
|----------------------------------|---------------------|
| Start-up time ²⁾ | 30 s |
| Warm-up time ³⁾ | 2 min ⁴⁾ |
| Response time (T ₉₀) | 90 s ⁵⁾ |

| | |
|---|--|
| Response time with flow-through adapter | 90 s at ≥ 0.5 l/min ⁵⁾ (recommended: 0.5 ... 1 l/min) |
|---|--|

1) Excluding cross-interferences to other gases.

2) Time to first reading

3) Time to specified accuracy

4) At +20 °C (+68 °F) ambient temperature

5) With standard PTFE filter

Inputs and outputs

| | |
|--------------------------------------|---|
| Operating voltage | 18 ... 30 VDC |
| Power consumption | Typical: 3 W Maximum: 6 W |
| Digital output | RS-485 (Modbus RTU) |
| Analog output | 3 × 4 ... 20 mA scalable, isolated |
| Analog output load | Minimum: 0 Ω Maximum: 500 Ω |
| Analog output accuracy | ±0.2 % of full scale at 25 °C (77 °F) |
| Analog output temperature dependence | 0.005 %/°C (0.003 %/°F) full scale |
| Analog input (optional) | 1 × 4 ... 20 mA (Ex ia) for external pressure or temperature sensor ¹⁾ |

1) The optional analog input is galvanically isolated and provides power for the connected external pressure sensor.

Compliance

| | |
|-------------------------------------|---|
| Electromagnetic compatibility (EMC) | EN61326-1, Industrial environment |
| Ex classification | Ex II 1/2 (1) G Ex eb mb [ia] IIB T3 Ga/Gb -40 °C ≤ Tamb ≤ +60 °C |
| IP rating | IP66 |

Operating environment

| | |
|-----------------------------|----------------------------------|
| Operating temperature range | -40 ... +60 °C (-40 ... +140 °F) |
| Operating humidity range | 0 ... 100 %RH |
| Storage temperature range | -40 ... +60 °C (-40 ... +140 °F) |
| Storage humidity range | 0 ... 90 %RH |
| Process pressure range | -500 ... +500 mbar(g) |
| Process temperature range | +0 ... +60 °C (+32 ... +140 °F) |
| Process flow range | 0 ... 20 m/s |

Mechanical specification

| | |
|---------------------|----------------------------|
| Weight | 3 kg (6.6 lb) |
| Thread type | 1.5" male NPT |
| Cable lead-throughs | 1 x M16x1.5 2 x M20x1.5 |

| Materials | |
|------------|-------------------------------|
| Probe body | AISI316L stainless steel, PPS |
| Filter cap | Sintered PTFE |

Options and accessories

| | |
|---|-------------|
| Configuration cable (RS485/USB) ¹⁾ | 257295 |
| Flow-through adapter | 258877 |
| Sintered PTFE filter (includes O-ring) | DRW249919SP |
| NPT 1.5" thread test plug | 257525SP |

1) Vaisala Insight software for Windows® available at www.vaisala.com/insight

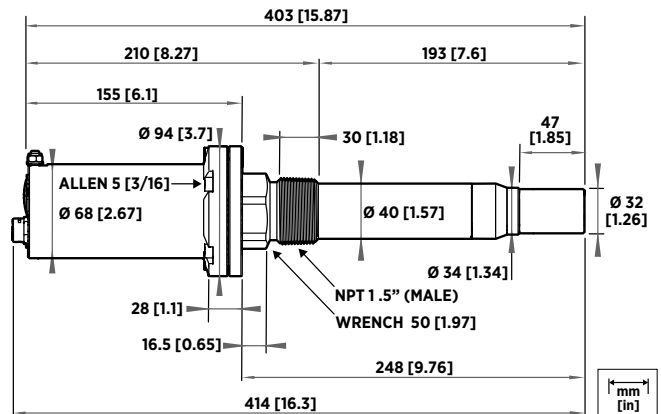

MGP261 dimensions

