

HX08 SERIES & H701

Detect Belt Loss, Coupling Shear, and Mechanical Failure



Hx08 Series and H701 adjustable current switches offer high performance, with a wide array of amperage range options. These products can accurately detect belt loss, coupling shear, or other mechanical failure on unit vents, exhaust fans, recirculation pumps, and other fixed loads down to as little as 1/5 HP.

SPECIFICATIONS

Sensor Power	Induced from monitored conductor
Insulation Class	600 Vac RMS (UL), 300VAC RMS (CE)
Frequency Range ²	50/60 Hz, On/Off status for Variable Frequency Drive (VFD) outputs at 12 to 115 Hz
Temperature Range	-15 to 60 °C (5 to 140 °F)
Humidity Range	10 to 90% RH non-condensing
Hysteresis	10% (typical)
Terminal Block Wire Size	H308: 22-16 AWG (0.3 to 1.3 mm ²) Others: 24-14 AWG (0.2 to 2.1 mm ²)
Terminal Block Torque	H308: 3.5 to 7 in-lbs (0.8 N-m) Others: 3.5 to 4.4 in-lbs (0.4 to 0.5 N-m)

WARRANTY

Limited Warranty 5 years

AGENCY APPROVALS

Agency Approvals UL 508 open device listing; CE: EN61010-1, CAT III, Pollution Degree 2, basic insulation



Retrofit or new construction

High performance devices in split- and solid-core housings

Adjustable trip point

Precise current trip point setting

Low setpoint

Minimum trip point as low as 0.5 A (H608)...no need for multiple wraps of the conductor through the sensor, even on loads as small as 1/5 HP

APPLICATIONS

- Detecting belt loss, coupling shear, and mechanical failure
- Verifying lighting circuit and other electrical service run times
- Monitoring status of industrial process equipment
- Monitoring status of critical motors (compressor, fuel, etc.)
- VFD output on/off status

Small size

Fits easily inside small enclosures

Self-gripping iris

Self-gripping iris on split-core housings for easy installation

Status LEDs

Status LEDs available for easy setup and local indication

DETECTS BELT LOSS/COUPLING SHEAR!

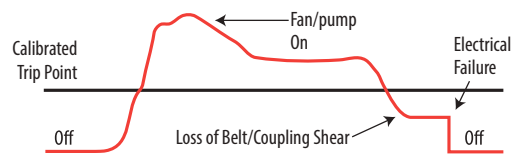

Now you can easily detect when drive belts slip, break, or pump couplings shear. In fact, a typical HVAC motor that loses its load has a reduction of current draw of up to 50%. That's why our sensors are the industry standard for status.

Notes: Do not use the LED status indicators as evidence of applied voltage.

If using this switch in an application that includes an electronically commutated motor (ECM), see Veris Application Note VN61, at www.veris.com.

VFD systems generate fields that can disrupt electrical devices. Ensure that these fields are minimized and are not affecting the sensor.

H308

Dimensional Drawing

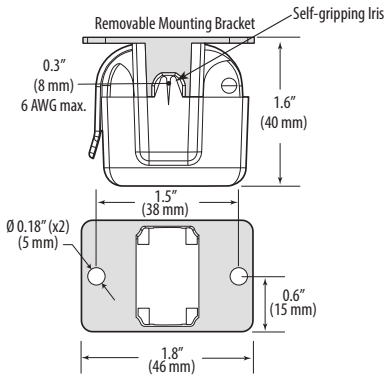

H608

Dimensional Drawing

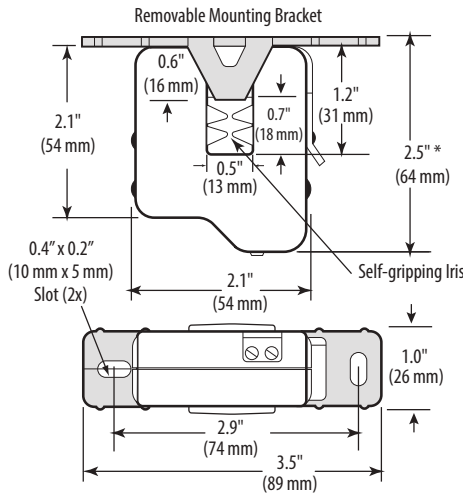

MONITORING FAN /PUMP MOTORS FOR POSITIVE PROOF OF FLOW

Wiring Diagram

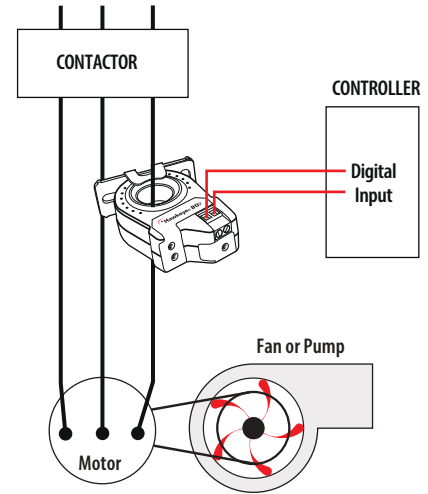

H708/701

Dimensional Drawing

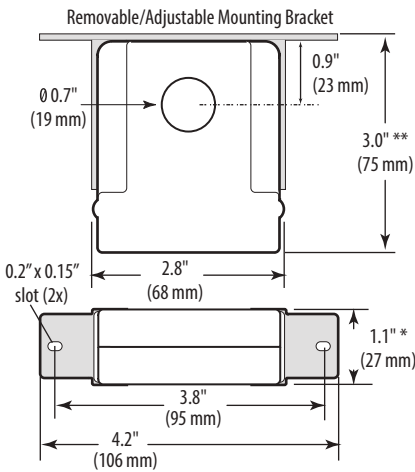

H908

Dimensional Drawing

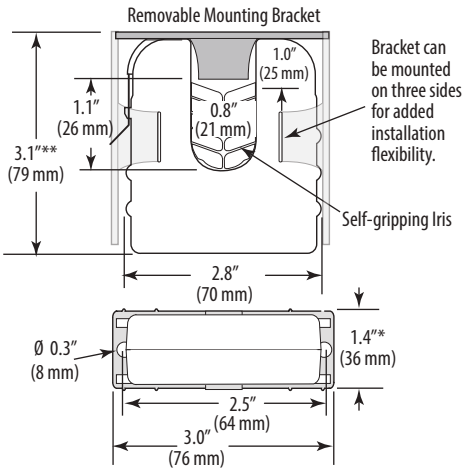

H808

Dimensional Drawing

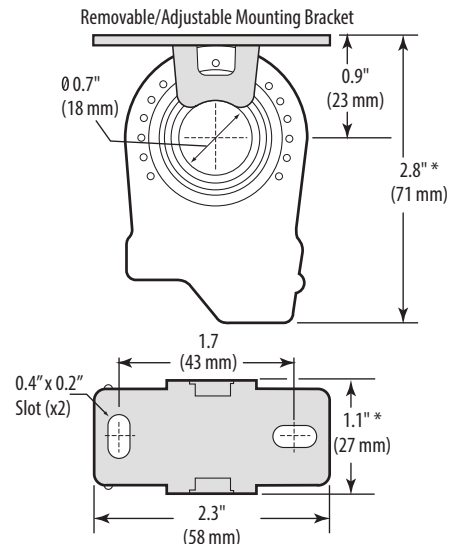

* Terminal block may extend up to 1/8" over the height dimensions shown.

** Slide switch may extend up to 1/4" over the height dimensions shown.

ORDERING INFORMATION

MODEL	AMPERAGE RANGE @ 50/60 HZ ONLY	STATUS OUTPUT (MAX.)	MIN. TRIP POINT	HOUSING	STATUS LED	UL	CE
H308	0.75 to 50 A	N.O. 1.0 A @ 30 Vac/dc	0.75 A or less	Split-Core	•	• ²	•
H608	0.5 to 175 A		0.5 A or less	Split-Core	•	• ¹	•
H701	1 to 135 A		1.0 A or less	Solid-Core	•	•	
H708	1 to 135 A		1.0 A or less	Solid-Core	•	•	
H808	0.75 to 50 A		0.75 A or less	Solid-Core	•	•	•
H908	2.5 to 135 A		2.5 A or less	Split-Core	•	•	•

1. Listed for use on 75 °C insulated conductors.

2. Product provides functional insulation only.