



### Features

- Designed for industrial spot-checking and field calibration
- Three models: accurate measurement ranges from  $-60$  to  $+60$  °C ( $-76$  ...  $+140$  °F)
- Vaisala DRYCAP® sensor with unique autocalibration function
- Sensor withstands condensation
- Data can be logged and transferred to a PC via MI70 Link software
- Traceable calibration (certificate included)
- Fast response, enhanced by sensor purge option
- Variety of sampling cell options for connection to pressurized processes

Vaisala DRYCAP® Handheld Dew Point Meter DM70 offers accurate and fast measurement for industrial dew point applications, such as compressed air, metal treatment, and plastics drying.

### Benefits

- Compact, small and light
- Intuitive user interface
- Low maintenance need due to superior long-term stability
- Sensor withstands condensation and fully recovers from getting wet

DM70 measures dew point temperature accurately over a wide measurement range. The probe may be inserted directly into pressurized processes, and it responds rapidly from ambient to process conditions. The DM70 meter is suitable for direct process dew point measurement in a wide temperature and pressure range. For more demanding applications, DM70 can be used with Vaisala sampling cells or with Vaisala DRYCAP® Sampling System DSS70A.

### Vaisala DRYCAP® technology

DM70 is fitted with the Vaisala DRYCAP® sensor. The sensor provides reliable, stable and high-performance dew point measurement. Autocalibration detects on-line possible measurement inaccuracies and automatically corrects dry-end drift in the calibration curve.

### Three probes to choose from

Three probe models, all with autocalibration, are available. The DMP74A and DMP74B models are both general purpose probes. The DMP74C model is specifically developed for SF<sub>6</sub> gas. The B and C probe models have an additional sensor purge feature that heats and dries the sensor, making the response from ambient to dry conditions exceptionally fast.

### Intuitive user interface

DM70 has a versatile and easy-to-use, menu-based user interface, a clear graphical LCD display, and datalogging capability. It can also be used as a tool for reading the output of fixed Vaisala dew point transmitters, such as DMT242, DMT132, DMT143, DMT152, and DMT340. DM70 displays one to three parameters at a time, either numerically or graphically. Several humidity units can be selected. In addition, DM70 includes conversion from gas pressure dew point to ambient pressure dew point. An analog output is also available.

### MI70 Link Windows® software

The optional Vaisala MI70 Link Windows® software and the USB connection cable form a practical tool for transferring logged data and real time measurement data from DM70 to a PC.

# Technical data

## DMP74A measurement performance

### Dew point

Measurement range (typical) -50 ... +60 °C (-58 ... +140 °F)

### Dew point accuracy vs. measurement conditions

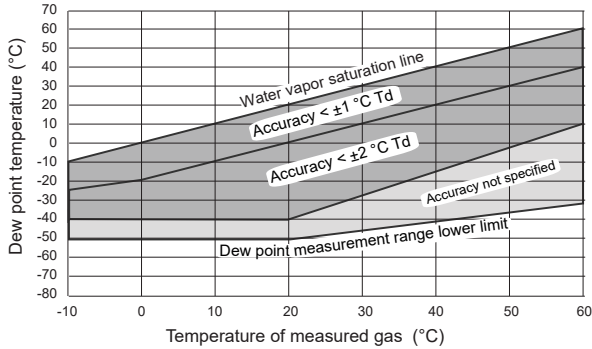

Accuracy (A probe) -40 ... +60 °C ±2 °C (±3.6 °F)  
(see graph)

### Response time

Flow rate 0.2 m/s, 1 bar pressure, +20 °C (+68 °F) 63 % [90 %]

0 → -40 °C T<sub>d</sub> (32 → -40 °F T<sub>d</sub>) 20 s [120 s]

-40 → 0 °C T<sub>d</sub> (-40 → 32 °F T<sub>d</sub>) 10 s [20 s]

Dew point sensor Vaisala DRYCAP® 180S

### Temperature

Measurement range -10 ... +60 °C (+14 ... +140 °F)

Accuracy at +20 °C (+68 °F) ±0.2 °C (±0.36 °F)

Typical temperature dependence of electronics ±0.005 °C/°C (±0.005 °F/°F)

Temperature sensor Pt100 RTD Class F0.1 IEC 60751

### Other variables available

Dew point converted to atmospheric pressure, ppm volume and ppm weight concentration, absolute humidity, mixing ratio, relative humidity

## Operating environment, all probe models

Operating temperature -10 ... +60 °C (+14 ... +140 °F)

Operating pressure for DMP74A, DMP74B 0 ... 20 bara (0 ... 290 psia)

Operating pressure for DMP74C 0 ... 10 bara (0 ... 150 psia)

Sample flow rate No effect on measurement accuracy

Measured gases Non-corrosive gases

EMC compliance EN 61326-1, Basic environment

## Mechanical specifications, all probe models

Probe material (wetted parts) Stainless steel (AISI 316L)

Sensor protection Sintered filter (AISI 316L)

Mechanical connection G1/2" ISO228-1 thread with bonded seal ring (U-seal)

IP rating IP65 (NEMA 4)

Weight 350 g (12 oz)

## DMP74B and DMP74C (for SF<sub>6</sub> gas) measurement performance

### Dew point

Measurement range (typical) -70 ... +30 °C (-94 ... +86 °F)

### Dew point accuracy vs. measurement conditions

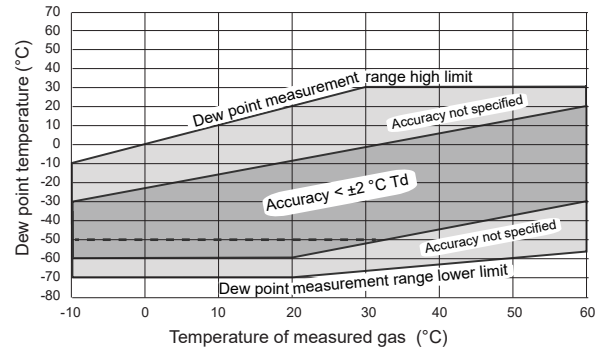

Dashed line:

For DMP74C the ±2 °C accuracy range is limited to -50 °C T<sub>d</sub> when used in SF<sub>6</sub> gas.

Accuracy (B and C probe) -60 ... +20 °C (-76 ... +68 °F) ±2 °C (±3.6 °F)  
(see graph)

### Response time

Flow rate 0.2 m/s, 1 bar pressure, +20 °C (+68 °F) 63 % [90 %]

0 → -60 °C T<sub>d</sub> (32 → -76 °F T<sub>d</sub>) 50 s [340 s]

-60 → 0 °C T<sub>d</sub> (-76 → 32 °F T<sub>d</sub>) 10 s [20 s]

Dew point sensor Vaisala DRYCAP® 180M

### Temperature

Measurement range -10 ... +60 °C (+14 ... +140 °F)

Accuracy at +20 °C (+68 °F) (-76 ... +68 °F) ±0.2 °C (±0.36 °F)

Typical temperature dependence of electronics ±0.005 °C/°C (±0.005 °F/°F)

Temperature sensor Pt100 RTD Class F0.1 IEC 60751

### Other variables available

Dew point converted to atmospheric pressure, ppm volume and ppm weight concentration

## MI70 measurement indicator

### Operating environment

Operating temperature	-10 ... +40 °C (+14 ... +104 °F)
Operating humidity	0 ... 100 %RH, non-condensing
Storage temperature	-40 ... +70 °C (-40 ... +158 °F)

### Inputs and outputs

Max. no of probes	2
PC interface	MI70 Link software with USB or serial port cable
Analog output	0 ... 1 VDC
Power supply	Rechargeable NiMH battery pack with AC adapter or 4 × AA size alkalines, type IEC LR6

Output resolution	0.6 mV
Accuracy	0.2 % full scale
Temperature dependence	0.002 %/°C (0.01 %/°F) full scale
Minimum load resistor	10 kΩ to ground

### Mechanical specifications

Housing classification	IP54
Housing materials	ABS/PC blend
Weight	400 g (14 oz)

### Compatibility

EMC compliance	EN 61326-1, portable equipment
----------------	--------------------------------

### Other

Menu languages	English, Chinese, Spanish, Russian, French, Japanese, German, Swedish, Finnish
----------------	--

Display	<ul style="list-style-type: none"> <li>LCD with backlight</li> <li>Graphic trend display of any parameter</li> <li>Character height up to 16 mm (0.63 in)</li> </ul>
---------	--

Alarm	Audible alarm function
Data logging capacity	2700 real time data points
Logging interval	1 s to 12 h
Logging duration	1 min ... memory full
Resolution	0.01 %RH, 0.01 °C/°F, 0.01 hPa, 0.01 a <sub>w</sub> , 10 ppm / 0.01 %CO <sub>2</sub>

### Battery operation time

Typical charging time	4 hours
Operation times	Continuous use: 48 h typical at +20 °C (+68 °F) Data logging use: Up to a month

## Spare parts and accessories

Weatherproof hard plastic carrying case	MI70CASE3
Soft carrying case	MI70SOFTCASE
MI70 USB PC connection cable (for use with MI70 Link software) <sup>1)</sup>	219687
Analog output signal cable	27168ZZ
Extension cable for probe (10 m (33 ft))	213107SP
Portable sampling system with case (see separate DSS70A datasheet)	DSS70A

### Connection cables for fixed Vaisala dew point transmitters

For DMT242 transmitter	27160ZZ
For DMT340 series	211339
For DMT152, DMT132, DMT143, DPT145, and DPT146 transmitters	219980SP

<sup>1)</sup> Vaisala MI70 Link software for Windows is available at [www.vaisala.com/mi70link](http://www.vaisala.com/mi70link).



MI70 indicator dimensions in millimeters (inches)

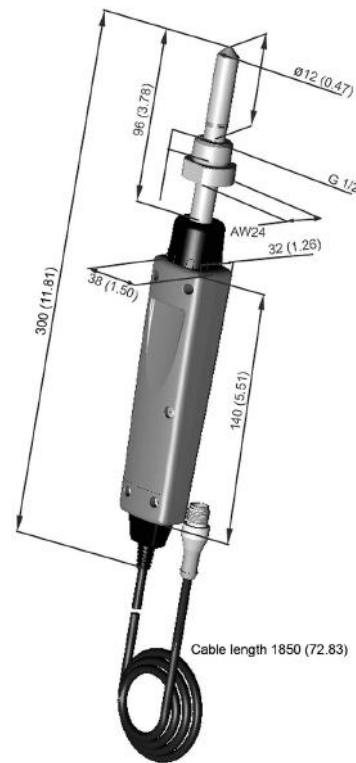

Probe dimensions in millimeters (inches)

