



# GMD20 Series Carbon Dioxide Transmitters

For Demand Controlled Ventilation Applications



## Features

- Versatile transmitters
- Reliable measurement with sensor inside the duct
- Incorporates Vaisala CARBOCAP® sensor - the silicon-based NDIR sensor
- Excellent long-term stability
- Negligible temperature dependence
- Ease of installation

The duct mounted Vaisala CARBOCAP® Carbon Dioxide Transmitter Series GMD20 is specially designed for demand controlled ventilation (DCV). The transmitters are easy to install and require no maintenance. The recommended calibration interval is five years.

### Vaisala CARBOCAP® Technology

The GMD20 series transmitters use the silicon-based Vaisala CARBOCAP® sensor. The simple structure and reference measurement capabilities make this single-beam, dual-wavelength NDIR sensor extremely stable and reliable.

The temperature and flow dependencies of the sensor are negligible. In addition, the measurement accuracy is not affected by dust, water vapor, and most chemicals.

### Versatile Transmitters

The GMD20 series transmitters can be used independently, or incorporated into building energy management systems. The series consists of duct mount units GMD20 and GMD20D. Version D is equipped with a display.

The compact sensor head design of the duct units fits inside the ventilation duct, eliminating the risk of leaking gaskets and measurement errors.

In addition to the standard 0 ... 20 mA, 4 ... 20 mA, and 0 ... 10 V outputs, there are two other options: one LonWorks® interface and a relay output. The relay output is standard with the display units.

### Improve Indoor Air at Minimal Energy Costs

The use of GMD20 series transmitters ensures the best possible control of air quality and results in considerable savings in energy consumption, maintenance, and recalibration costs.

# Technical Data

## Measurement Performance

### Carbon Dioxide

Measurement range	0 ... 2000 ppm (Nominal; can be calibrated for other ranges: 0 ... 5000 ppm, 0 ... 10 000 ppm, 0 ... 20 000 ppm)
-------------------	---

Accuracy (including repeatability, non-linearity and calibration uncertainty)  $\pm$  (2 % of range + 2 % of reading)

Long-term stability <  $\pm$ 5 % of range / 5 years

Response time (63 %) 1 minute

Warm-up time 1 minute, 15 minutes full specifications

## Operating Environment

Operating temperature -5 ... +45 °C (+23 ... +113 °F)

Operating humidity 0 ... 85 %RH, non-condensing

Flow velocity 0 ... 10 m/s

Electromagnetic compatibility EN61326-1, Generic Environment

## Inputs and Outputs

Outputs 0 ... 20 or 4 ... 20 mA and 0 ... 10 V

Optional outputs

- Relay
- LonWorks® interface

Resolution of analog outputs 8 bits

Recommended external load

- Current output: max. 500  $\Omega$
- Voltage output: min. 1 k $\Omega$

Operating voltage Nominal 24 VAC/DC (18 ... 30 VDC)

Connections Screw terminals, wire size 0.5 ... 1.5 mm<sup>2</sup>

Power consumption < 2.5 W

## Mechanical Specifications

Housing material ABS plastic

IP rating (housing) IP65

### Weight

GMD20	140 g (5 oz)
GMD20D	170 g (6 oz)

## Spare Parts and Accessories

Display and relay option for GMD20 GMI21

Relay output option GMR20

LonWorks® module with CO<sub>2</sub> signal GML20  
(not available when display option is added)

Serial COM adapter 19040GM

Hand-held meter for field verification GM70

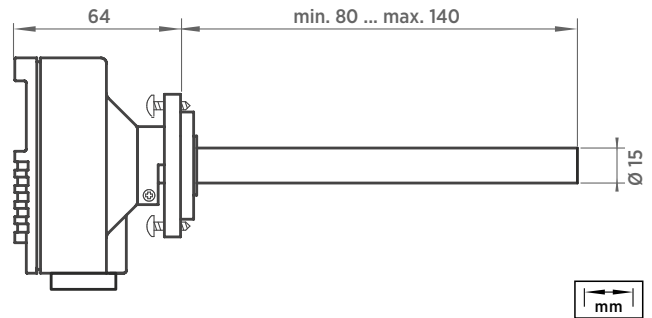

GMD20 Dimensions

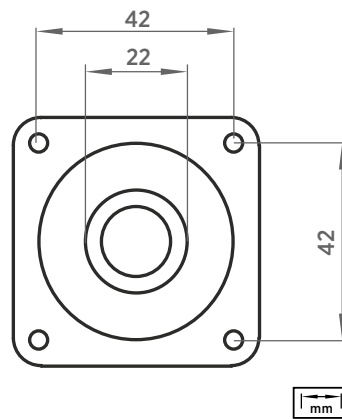

GMD20 Mounting Plate Dimensions

