



HM70 Handheld Humidity and Temperature Meter

For spot-checking and field calibration



Features

- Designed for spot-checking and field calibration
- Multilingual user interface
- Shows measurement trends graphically
- Proven Vaisala HUMICAP® sensor technology
- 3 probe alternatives, temperature measurement range -70 ... +180 °C (-94 ... +356 °F)
- 2 probes: also dew point and CO₂ probes can be connected simultaneously
- Displays various humidity parameters
- Sensor preheat and chemical purge options for demanding conditions
- Data can be logged and transferred to a PC via MI70 Link software
- 6-point traceable calibration (certificate included)

Vaisala HUMICAP® Handheld Humidity and Temperature Meter HM70 is designed for demanding humidity measurements in spot-checking applications. It is also ideal as an on-site calibrator for Vaisala's fixed humidity instruments.

Vaisala HUMICAP® technology

HM70 incorporates the world-class HUMICAP® sensor, one of the most reliable and stable sensors on the market. The HUMICAP® sensor copes well with chemical interference and provides accuracy that lasts in demanding conditions.

Chemical purge

The chemical purge option maintains measurement accuracy in environments with high concentrations of chemicals. The sensor preheat option reduces measurement delays as it keeps the sensor dry when the probe is inserted into hot and humid processes.

Three probes to choose from

HMP75 is a general purpose probe, whereas HMP76 is a long, stainless steel probe especially suitable for spot-checking in ducts. HMP77 is a small probe at the end of a 5-meter cable. The probe is ideal for difficult-to-reach areas and for on-site calibration of Vaisala's process transmitters. In addition, HM70 supports the use of Vaisala's dew point, carbon dioxide, and moisture in oil probes, allowing measurements in several multiparameter applications.

MI70 Link Windows® software

The optional Vaisala MI70 Link Windows® software and the USB connection cable form a practical tool for transferring logged data from HM70 to a PC.



On-site calibration with HM70 Handheld Meter

Technical data

HMP75, HMP76, and HMP77 measurement performance

Relative humidity

Measurement range	0 ... 100 %RH
Accuracy: ^{1) 2)}	
At +15 ... +25 °C (+59 ... +77 °F)	±1 %RH (0 ... 90 %RH) ±1.7 %RH (90 ... 100 %RH)
At -20 ... +40 °C (-4 ... +104 °F)	±(1.0 + 0.008 x reading) %RH
At -40 ... +180 °C (-40 ... +356 °F)	±(1.5 + 0.015 x reading) %RH
Factory calibration uncertainty (+20 °C / +68 °F)	±0.6 %RH (0 ... 40 %RH) ±1.0 %RH (40 ... 97 %RH)
Response time (90%) at +20 °C (+68 °F) in still air:	
HMP75 (with standard plastic grid)	17 s
HMP76 (with standard sintered bronze filter)	60 s
HMP77 (with standard plastic grid and stainless steel netting)	50 s
Typical long-term stability	Better than 1 %RH / year

Temperature

HMP75 measurement range	-20 ... +60 °C (-4 ... +140 °F)
HMP76 measurement range	-50 ... +120 °C (-58 ... +248 °F)
HMP76 short time measurement range	-50 ... +180 °C (-58 ... +356 °F)
HMP77 measurement range	-70 ... +180 °C (-94 ... +356 °F)
Accuracy at +20 °C (+68 °F)	±0.2 °C (±0.36 °F), see the graph below

Output parameters

Dew point, frost point, absolute humidity, mixing ratio, wet bulb temperature, water content, vapor pressure, saturation vapor pressure, enthalpy, water activity

1) Including non-linearity, hysteresis, and repeatability.
2) Defined as ±2 standard deviation limits.

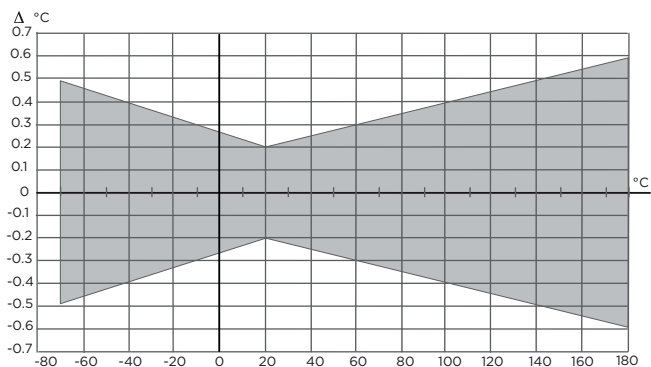

Temperature measurement accuracy over temperature range

HMP75, HMP76, and HMP77 general specifications

Humidity sensor	HUMICAP® 180R HUMICAP® 180RC (chemical purge, sensor preheat)
Temperature sensor	Pt100 RTD Class F0.1 IEC 60751
Operating temperature range for electronics	-40 ... +60 °C (-40 ... +140 °F)
Standard sensor protection	
HMP75	Plastic grid
HMP76	Sintered bronze filter
HMP77	Grid with SS netting

HMP75, HMP76, and HMP77 mechanical specifications

IP rating	IP65 (NEMA 4)
Housing material	ABS/PC blend
Probe material	Stainless steel (AISI316L)
Probe cable length (between indicator and probe handle)	1.9 m (6.2 ft)
Probe cable length of HMP77 (from handle to the root of probe)	5.0 m (16 ft)
Probe diameter	12 mm (0.47 in)
Weight	
HMP75	250 g (8.8 oz)
HMP76	350 g (12 oz)
HMP77	500 g (18 oz)

MI70 measurement indicator

Operating environment

Operating temperature	-10 ... +40 °C (+14 ... +104 °F)
Operating humidity	0 ... 100 %RH, non-condensing
Storage temperature	-40 ... +70 °C (-40 ... +158 °F)

Inputs and outputs

Max. no of probes	2
PC interface	MI70 Link software with USB or serial port cable
Analog output	0 ... 1 VDC
Power supply	Rechargeable NiMH battery pack with AC adapter or 4 × AA size alkalines, type IEC LR6
Output resolution	0.6 mV
Accuracy	0.2 % full scale
Temperature dependence	0.002 %/°C (0.01 %/°F) full scale
Minimum load resistor	10 kΩ to ground

Mechanical specifications

Housing classification	IP54
Housing materials	ABS/PC blend
Weight	400 g (14 oz)

Compatibility

EMC compliance	EN 61326-1, portable equipment
----------------	--------------------------------

Other

Menu languages	English, Chinese, Spanish, Russian, French, Japanese, German, Swedish, Finnish
Display	<ul style="list-style-type: none"> LCD with backlight Graphic trend display of any parameter Character height up to 16 mm (0.63 in)
Alarm	Audible alarm function
Data logging capacity	2700 real time data points
Logging interval	1 s to 12 h
Logging duration	1 min ... memory full
Resolution	0.01 %RH, 0.01 °C/°F, 0.01 hPa, 0.01 a _w , 10 ppm / 0.01 %CO ₂

MI70 battery operation time

Typical charging time	4 hours
Operation times	
Continuous use	48 h typical at +20 °C (+68 °F)
Data logging use	Up to a month

Spare parts and accessories

Cables

Analog output signal cable	27168ZZ
Connection cable for HMT310 series	DRW216050SP
Connection cable for HMP155	221801
Connection cable for TMP115, HMD60 series, HMP60 and HMP110 series, HMW90 series, HMDW110 series, and GMW90 series	219980SP
1-m (3.3-ft) flat extension cable for 219980SP	CBL210649SP
Probe extension cable (10 m)	213107SP
Connection cable for HMT330 and HMT120/130	211339

Carrying cases

Weatherproof carrying case for MI70 and short probe (HMP75/77)	MI70CASE3
Weatherproof carrying case for MI70 and long probe (HMP76)	MI70CASE4
Soft carrying case for MI70 and short probe (HMP75/77)	MI70SOFTCASE

Probe accessories

Plastic PC grid filter (HMP75)	6221
Membrane filter (HMP75)	10159HM
Sintered bronze filter (HMP75)	DRW212987SP
Plastic PPS grid filter (HMP76/77)	DRW010276SP
Sintered stainless steel filter (HMP76/77)	HM47280SP
Sintered bronze filter (HMP76 standard)	DRW212987SP
PPS grid with SS netting (HMP77 standard)	DRW010281SP
Probe holder (only for HMP76)	HM36915

Others

Measurement indicator	MI70
USB PC connection cable (for use with MI70 Link software) ¹⁾	219687
Rechargeable battery for MI70	26755

¹⁾ Vaisala MI70 Link software for Windows is available at www.vaisala.com/mi70link.

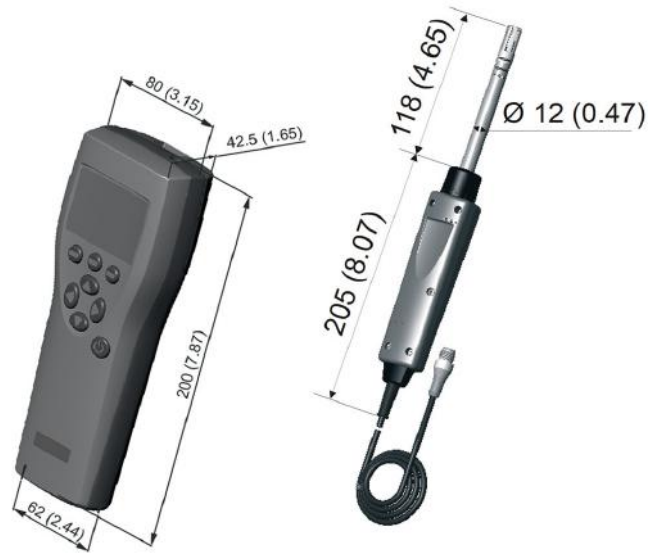

MI70 indicator and HMP75 probe dimensions in mm (inches)

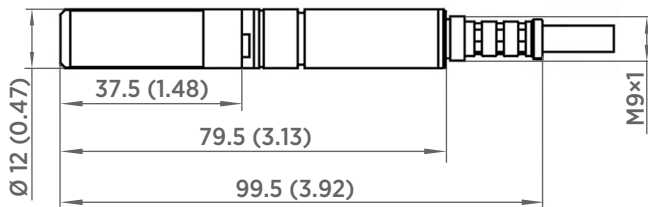

HMP77 probe dimensions in mm (inches)

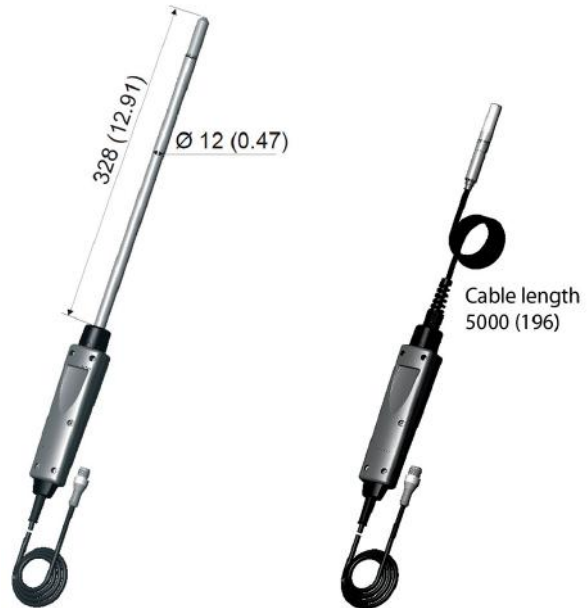

HMP76 and HMP77 probe with cable, dimensions in mm (inches)

