

# POSITIVE DISPLACEMENT FLOW METER MT SERIES



## DESCRIPTION

MT series meter is positive displacement meter for liquids. They are designed for liquid metering both in transfer and process control applications. Thanks to their design they are easy to keep and can suit a wide range of applications.

## APPLICATIONS

- Check of loading/unloading operations of fuel and petrochemical products in fuel bulk plants and/or refineries
- Wine manufacturer
- Oil and gas plant

## FEATURES

- Excellent stepless adjusting mechanism allow a micro adjustment of the meter
- High accuracy and repeatability over the widest range of flow; superior accuracy at constant flow
- Low maintenance, no metal-to-metal contact in measuring chamber. long life service
- Low pressure loss, a true gravity flow meter
- Accuracy regardless of pressure fluctuations, temperature variation, viscosity
- Choice of aluminum, cast iron and stainless steel materials of construction

## TECHNICAL DATA

Model	MT-40-1	MT-50-1	MT-80-1	MT-100-1	MT-150-1
Size	40mm / 1-1 / 2"	50mm / 2"	80mm / 3"	100mm / 4"	150mm / 6" and 100mm / 4" for option
Flow Range	25~250L / min	55~550L / min	115~1150L / min	170~1700L / min	300~3000L / min
Volume Per Revolution	0.309L	0.681L	1.839L	5.102L	14.87L
Max. Pressure	10Bar				
Accuracy	± 0.2%				
Repeatability	≤ 0.07%				
Standard Measurement	Liter / US Gallon / IMP Gallon				
Dimension	51×46×49cm	51×46×49cm	62×54×57cm	76×64×72cm	80×65×90cm
Net Weight	23kg	26kg	40kg	70kg	130kg
Gross Weight	25kg	28kg	47kg	93kg	180kg
Package	1pc / Strong Yellow Paper Carton			1pc / Wooden Case	

Remark: 4" or 6" available for option for M-150-1 (6") meter



**MT-50-KX-1**



**MT-50-NX-1**



**MT-80-G-1**

## TECHNICAL DRAWINGS

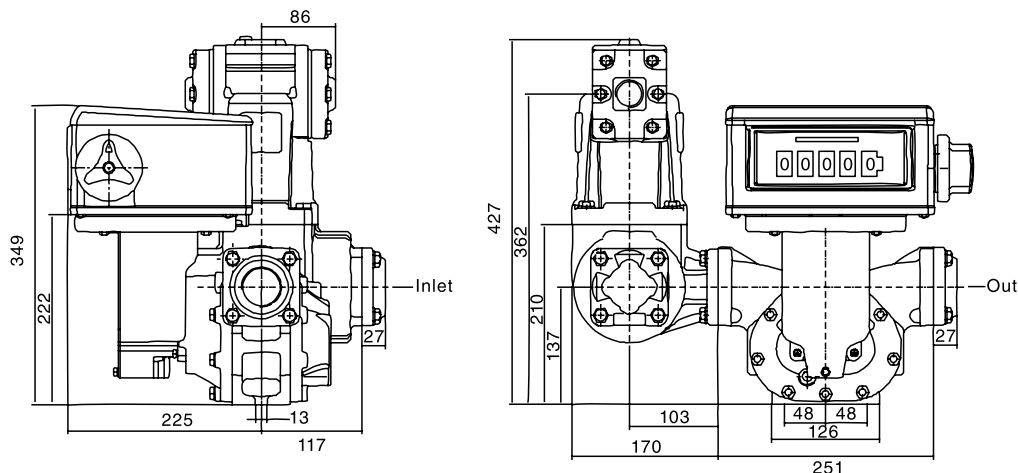

MT-40-1 Meter Dimension

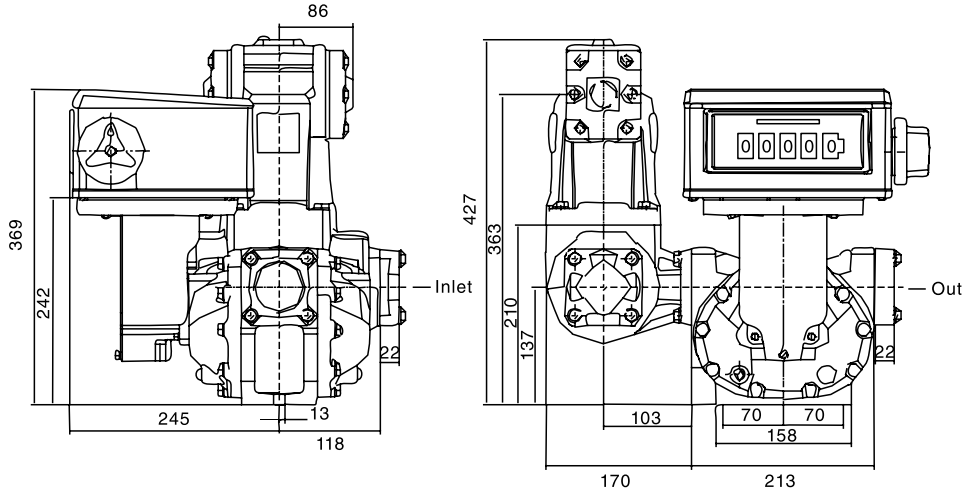

MT-50-1 Meter Dimension

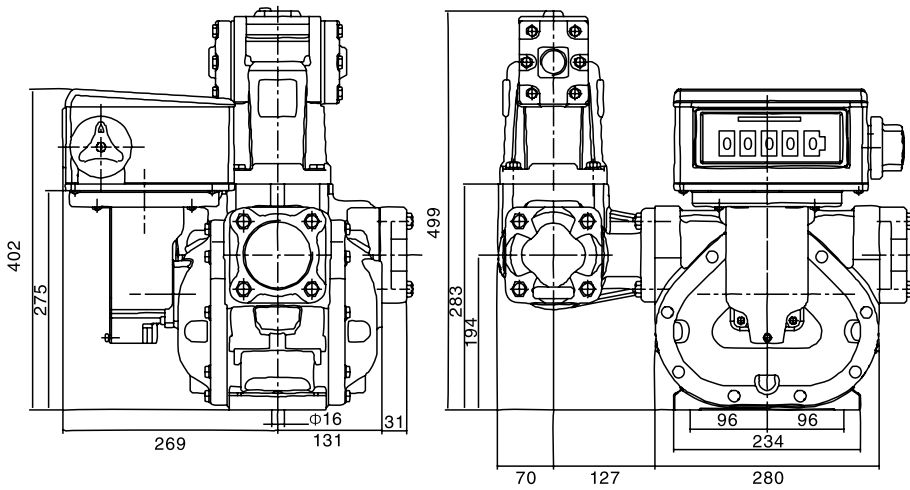

MT-80-1 Meter Dimension

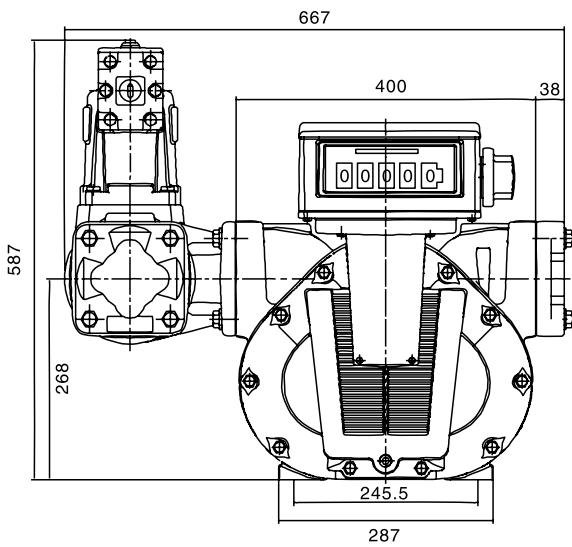

MT-100-1 Meter Dimension

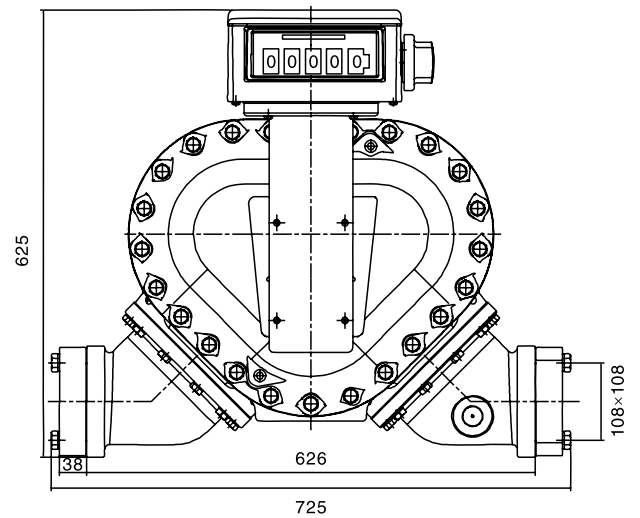

MT-150-1 Meter Dimension

# MODEL ACCESSORIES

	NO STRAINER NO AIR ELIMINATOR NO VALVE	STRAINER NO AIR ELIMINATOR NO VALVE	STRAINER AIR ELIMINATOR NO VALVE	NO STRAINER NO AIR ELIMINATOR VALVE	STRAINER NO AIR ELIMINATOR VALVE	STRAINER AIR ELIMINATOR VALVE
COUNTER NO PRINTER NO PRE-SET						
COUNTER PRINTER NO PRE-SET						
COUNTER PRE-SET NO PRINTER						
COUNTER PRINTER PRE-SET						
NO COUNTER NO PRINTER NO PRE-SET						

# MODEL DESCRIPTION

## MT-50-CX-1

