



**Dpstar Group**

# **Electrical Resistance Heat Tape & Heat Tube**

[www.dpstar.com.my](http://www.dpstar.com.my)

### Bulk Tape

— for in-place heat trace applications

Wide selection of resistances for your voltage, wattage and temperature needs

- Most economical purchase option
- Custom engineering available for your project
- Large and small power lead termination kits available
- 4 conductors (1/2" wide), 2 conductors (1/4" wide), or single conductor (1/6" wide)
- Available in 50 or 100 foot rolls

### Custom Heaters

— engineered for your application

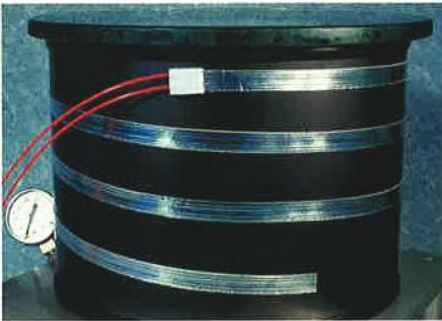

Custom heater application



Heat tracing application

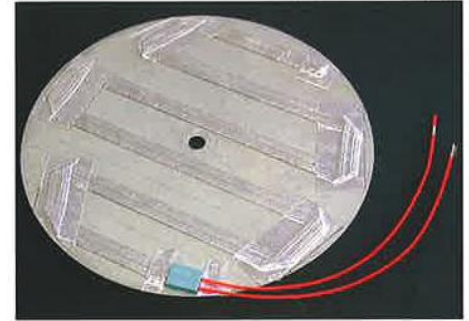

Flat Surface application

- Engineered to your desired length and wattage
- Electrically terminated, sealed and tested
- Ready to install, simply peel and stick
- Easy application enhances installation
- Fixed temperature thermostats available

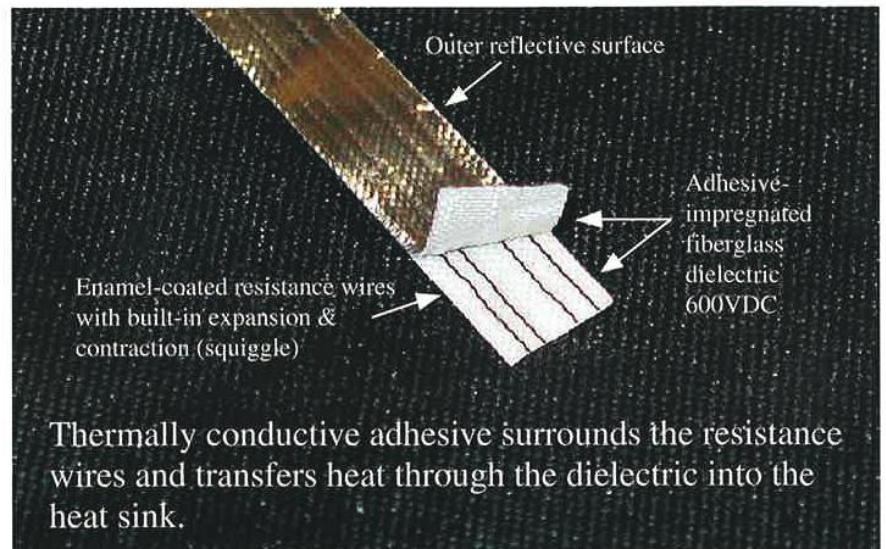

- 16 Series tape : Silicone adhesive for commercial/ with off-the shelf availability
- 28 Series tape : Acrylic adhesive for aerospace/ vacuum applications with low outgassing requirement

Thermal energy is transferred directly to the object through both conductive and radiant modes of heat. Additional radiant energy emitted away from the object is reflected back onto it. This ensures the most efficacious conversion of electrical energy to thermal energy directly to the tube being heated.

### Markets

- Aerospace
- Satellites
- Heat Tracing
- Heated Sample Lines

### Features

- AC or DC operation
- Input voltage from 1v - 277v
- Lengths up to 450' continuous
- Temperatures up to 450 degrees F
- Aluminum, Fiberglass cloth or Kapton
- 1/2", 1/4" or 1/6" width
- Silicone or low-outgassing acrylic adhesive
- Thickness less than 1/64"
- Efficient thermal transfer

### Configurable Circuitry Options:

- Manage input current
- Maintain wattage as temperature increases
- Reduced wattage holding circuit
- Over-temp protection
- One tape designed for multiple temperatures
- 3-phase operation



Layer 1: Outer, radiant heat reflective surface

Layer 2: Thin, flexible dielectric

Layer 3: Resistive Heating Element

Layer 4: Thin, flexible dielectric

Layer 5: Adhesive

Heated Material

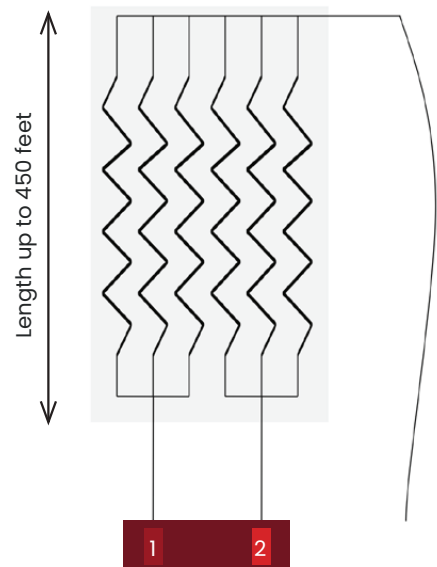
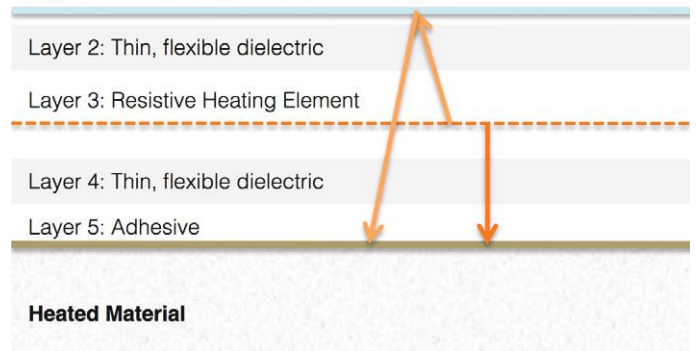

Multi-circuit example

Circuit 1 achieves temperature 1

Circuit 2 achieves temperature 2

Circuit 1 & 2 achieves temp 3



### Heat Tape Specifications

Description	Silicone Adhesives (-16 series)	Acrylic Adhesives (-28 series)
Operating Temperature Range	-100°C to +250°C	-40°C to +150°C
Outgassing ... TML/VCM	1.047% / .322%	1.000% / .100%
Adhesion to etched aluminum oz/inch width	25@ +150°C 450@ -100°C	15@ +125°C 50@ -100°C
Overall Thickness Applied	.025"	.028"
Dielectric Strength	600 vdc	600 vdc

**Note:** In applications exposed to weather, water, mechanical abuse or solvents, tapes will require additional protection. If there is any potential for moisture to come in contact with the heat tape, we recommend a ground circuit should be installed between the aluminum top surface of the heating tape and the grounded metal heat sink to which it is applied.

### Heat Tape Specifications

- Determine the length (L) of the heating tape needed to give even distribution of the total wattage (Tp) over the surface of the object to be heated.
- Determine the amount of power necessary for your application. The total wattage (Tp) required to maintain the object to be heated at the desired temperature can be calculated as follows (based on temperature maintenance only. Does not provide for rapid warm-up or heat losses/gains due to fluids in tube):

a. Calculation Flat Surface Heating  
 $T_p = P \times A \times \Delta T$

a. Calculation Tube and Pipe Heating  
 $T_p = P \times L_{\text{tube}} \times \Delta T$

**Where:**

P = Watts required to maintain temperature per square foot per degree F temperature rise (see table below)

A = Heated Area, square feet

$\Delta T$  = Temperature rise, °F above

**Where:**

P = Watts required per lineal foot of tube per degree F temperature rise (see table below)

L = Length of tube, feet

$\Delta T$  = Temperature rise, °F above ambient

Insulation Thickness	Bare	.5"	1"	2"
P Watts / sq. ft. / F	.3	.15	.10	.07

Insulation Thickness	Tube Diameter			
	1/4"	1/2"	1"	2"
Bare	.15	.13	.21	.4
1/2"	.07	.09	.13	.20
1"	.04	.05	.08	.11

**3. Calculate the Ohms / Foot of Tape**

$E^2 / T_p \times L$  where:

E = Your operating voltage.

$T_p$  = Total from item 2.

L = Length of tape from item 1

**4. Calculate Watts / Foot of Tape**

$T_p / L$

**5. See The Data Table Below**

From the data table select the tape with the approximate ohms/foot as calculated in step "3" and equal or greater maximum watts/foot capacity as calculated in step "4".

B. (1) Determine the length ( $L_{\text{tape}}$ ) of heating tape needed to give even distribution of the total wattage ( $T_p$ ) over the surface of the object to be heated. Calculate the surface area in square inches. For 100% coverage with 1/2" wide tape, divide by 6 in<sup>2</sup>/ft. For 100% coverage with 1/4" wide tape, divide by 3 in<sup>2</sup>/ft.

$$(2) \text{ Calculate Ohms/ foot of Tape} = \frac{E^2}{T_p \times L_{\text{tape}}}$$

**Where:**

E = Your operating voltage (DC or AC)

$T_p$  = Total wattage from Step A

$L_{\text{tape}}$  = Length of tape from item B (1).

$$(2) \text{ Calculate Watts/ foot of Tape} = \frac{T_p}{L_{\text{tape}}}$$

D. Proceed to the "How to Order" section below. From the data table select tape with the approximate ohms/foot as calculated in Step B(2) and equal or greater maximum watts/ foot capacity as calculated in Step "C". Do not exceed the maximum watts per foot.

### Resistance Matrix

Tape Width	1/6"		1/4"			1/2"			
Number of Conductors	1		2			4			
Part Number	ohms per foot	Max. watts per ft.(4)	ohms per ft. see notes		Max. watts per ft.(4)	ohms per ft. see notes			Max. watts per ft.(4)
			(1)	(2)		(1)	(3)	(2)	
A -16 or A - 28	1.9	25	.9	3.8	40	.5	1.9	7.6	70
B -16 or B - 28	3.2	25	1.6	6.4	40	.8	3.2	12.8	70
C -16 or C - 28	4.0	23	2.0	8.0	35	1.0	4.0	16.0	62
D -16 or D - 28	4.9	20	2.4	9.8	30	1.2	4.9	19.6	52
E -16 or E - 28	7.0	25	3.5	14.0	40	1.7	7.0	28.0	70
F -16 or F - 28	8.8	23	4.4	17.6	35	2.2	8.8	35.2	62
G -16 or G - 28	10.8	20	5.4	21.6	30	2.7	10.8	43.2	52
H -16 or H - 28	13.2	20	6.6	26.4	30	3.3	13.2	52.8	52
J -16 or J - 28	21.3	13	10.6	42.6	20	5.3	21.3	85.2	32
K -16 or K - 28	26.8	10	13.4	53.6	16	6.7	26.8	107.2	25

**How to Order Table Notes 1-4**

(1) Ohms/foot with all conductors in parallel connection.



(2) Ohms/foot with all conductors in parallel connection.

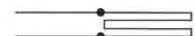

(3) Ohms/foot with conductors in parallel/series connection.

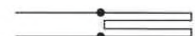

(4) Maximum wattage per lineal foot when applied to a metal heat sink at room temperature. Reduce these ratings linearly to zero watts output @500°F. Use of Dpstar Terminal is encouraged to insure thermal grounding of Heat Tape along its entire length.

Notes : Other custom resistances are available, ie., .04, .11, .19, .39, .59, or 1.1

Adhesion to heat sink along entire length is important to prevent burnout when tape is used near maximum wattage rating.

### Heat Tape

— precision machine wrapped heated tubing

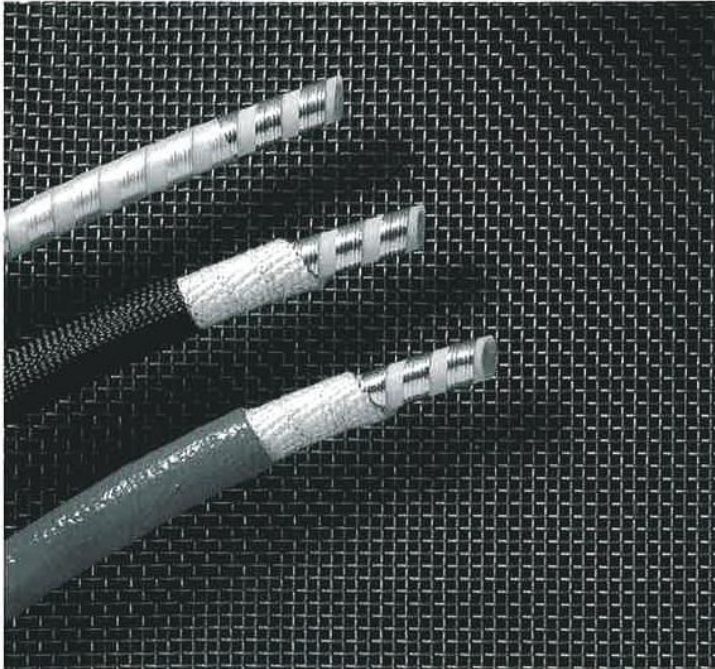

#### Standard

- Heat Traced With Heat Shrink Cover

#### Heavy Duty

- "Standard" plus insulation & nylon braid

#### Industrial Strength

- "Heavy Duty" plus silicone jacket scuffcoat

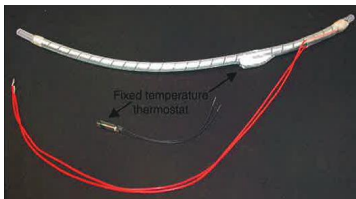

Fixed Temperature  
Internal Thermostat



Power and/or control cables  
can run length of the hose

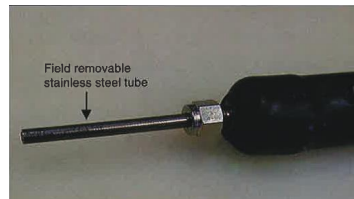

Field removable stainless  
steel tube

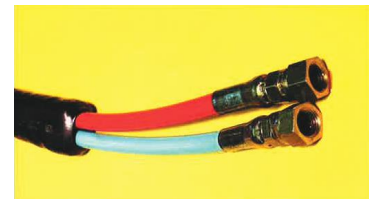

Customized end fittings

- Reflective heat process provides quick startups and lower overall wattage requirements.
- Thermally conductive adhesive enhances heat transfer for lightweight yet rugged construction.
- Automated wrapping process provides short manufacturing lead time; 10days ARO.

### Cost-Effective Applications Include :

- Stack Sampling
- Gas Analysis
- Viscous Chemicals
- Adhesives
- Hot Melt
- Emissions
- Foods
- Freeze Protection
- Lubricants
- Viscosity Control

### Heat Tube For Natural Gas

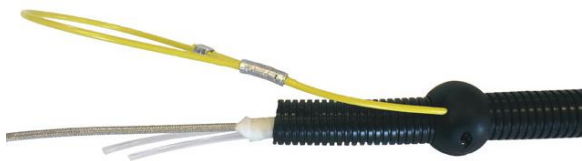

Optional strain relief



Optional armored end



Optional Firesleeve Cover



Optional Polyamide 12 cover

### Markets

- Midstream (Transmission to processing)
- Chemical Processing
- Power Generation
- Refineries
- Utilities
- Transportation (Natural Gas Vehicles)
- Fertilizer Production
- Hydrogen Production
- Some Manufacturing (Fabrics, Glass, Steel, Plastics, Paint)

### Features

- Light weight
- Flexible
- Field replaceable tubing
- Temperature indicator lights
- High thermal efficiency
- Long life span
- Robust UV and chemical resistant outer cover

### Applications

- Moisture Analysis
- Sample purity / quality monitoring

### Available Accessories

- Strain Relief at user defined locations
- Field replaceable moisture monitoring tube
- High performance insulation
- Pass through power
- Heated blanket accessory

### Heat Tube For Natural Gas

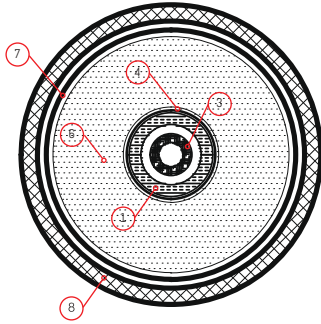

Standard Natural Gas Line

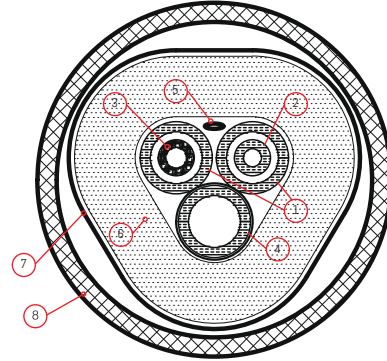

Natural Gas Line With Moisture Monitoring

- 1/4" OD FEP teflon tubing (carrier tubes) (1)
- Optional field replaceable 1/8" Teflon tubing for separate moisture monitoring (2)
- Field replaceable 1/8" OD stainless steel or Nylon 11 natural gas tube (3)
- Clayborn heat trace at nominal 7 watts per foot (4)
- Self-regulating to 120F with 175F over-temp protection
- Voltage options include 12, 24, 108, 120, 208 or 240
- End fittings available:
  - Full range of standard Parker end fittings
  - Robust "armored ends" with field replaceable stainless steel fittings
- Integrated thermocouple or RTD temperature monitor (5)
- Nomex felt insulation (6)
- Continuous internal nylon braid kellum grip (foundation for strain reliefs) (7)
- Outer cover options:
  - High temperature silicone firesleeve
  - Corrugated polyamide 12 (8)



### Heat Tube For Stack Emissions Monitoring

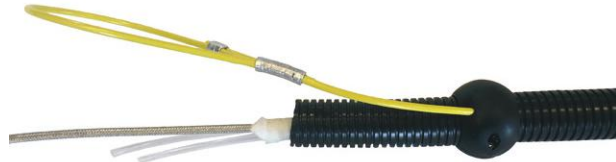

Optional strain relief



Optional Polyamide 12 cover



Optional controller

### Markets

- Power Generation
- Chemical Processing
- Refineries
- Equipment / Machinery manufacturers
- Engine Testing

### Applications

- CEMS-Continuous Emission Monitoring
- RATA Testing – Mobile System Monitoring

### Features

- Light weight
- Flexible
- High thermal efficiency
- Long life span
- UV and chemical resistant outer cover
- Unique heater wiring options allow for extensive electrical configurations

### Available Accessories

- Strain Relief(s) at user defined locations
- High performance insulation
- 15, 20 or 30 amp, 120v controllers
- Up to (22) Pass through power, control, or thermocouple wires
- Custom labeling
- Temperature indicator lights
- Early wire or tubing exit from outer cover

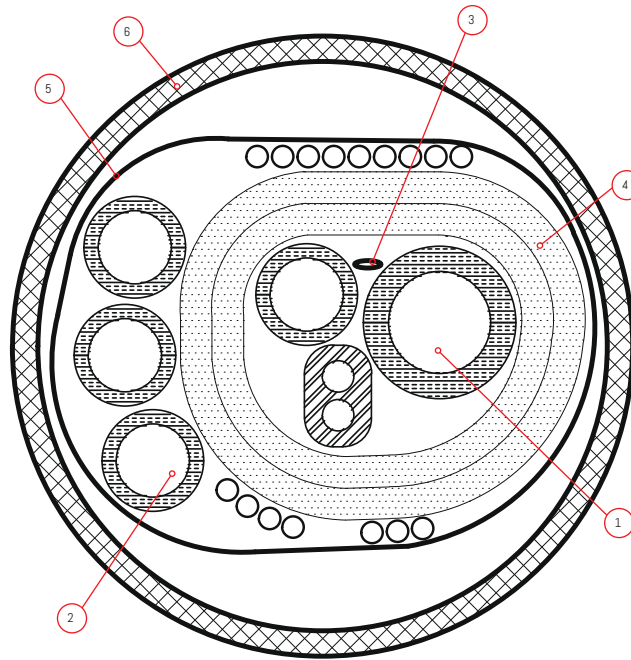

Standard CEMS

- Heated zone **(1)**
  - Up to (6) heated teflon tubes (PFA or PTFE)
  - OR - Up to (2) heated stainless steel tubes (304 or 316)
- Un-heated zone **(2)**
  - Up to (6) un-heated Teflon tubes (PFA or PTFE)
  - OR - Up to (1) un-heated stainless steel tube (304 or 316)
- Maintain Temperatures up to 400F (204C)
- Control options:
  - External control via integral thermocouple or RTD
  - Self regulated
- Voltage options: 120, 208, 240, 277
- End fittings available :
  - Full range of standard Parker end fittings
  - Robust "armored ends" with field replaceable stainless steel fittings
- Integrated thermocouple or RTD temperature monitor **(3)**
- Nomex felt insulation **(4)**
- Continuous internal nylon braid kellow grip (foundation for strain reliefs) **(5)**
- Corrugated polyamide 12 outer cover **(6)**

### Heat Tube For Chemical Analysis



Optional Polyamide 12 cover



Optional controller

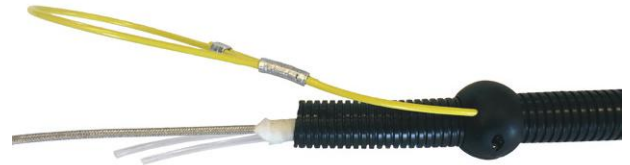

Optional strain relief



Optional Firesleeve Cover

### Markets

- Pharmaceutical manufacturers
- Analyzer manufacturers
- Testing laboratories

### Applications

- pH Analysis
- Partition Analysis
- Liquid Extraction
- Stability Testing
- Sample / Substance temperature maintenance
- Moisture analysis
- Tubes used integrally within analyzers

### Features

- Light weight
- Flexible
- Field replaceable tubing
- High thermal efficiency
- Long life span
- UV and chemical resistant outer cover

### Available Accessories

- Strain Relief at user defined locations
- High performance insulation
- Pass through power, control, or thermocouple wiring
- 15, 20 or 30 amp, 120v controllers available
- Ability to heat trace any tubing types including Teflon, Nylon, Stainless Steel, Titanium, Poly, Silicone

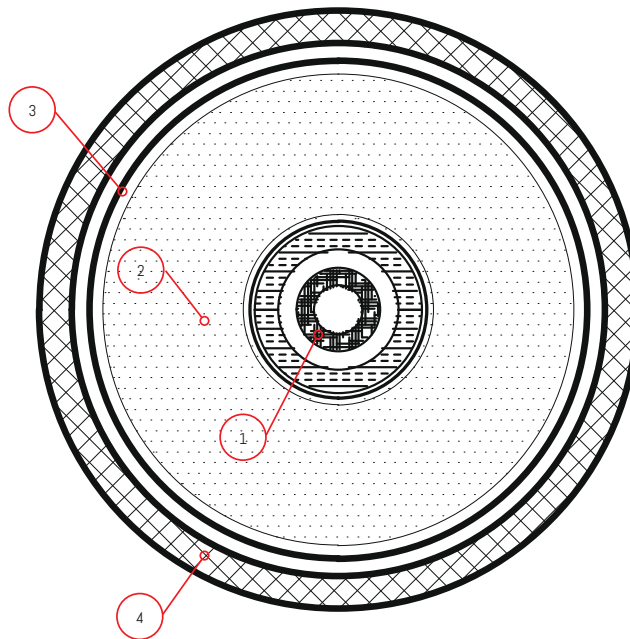

Standard CEMS

- Field replaceable 1/8" OD stainless steel carrier tube (larger OD if needed) **(1)**
- Control style:
  - Self-regulating to 120F with 175F over-temp protection
  - Externally controlled via integral thermocouple or RTD
- Voltage options include 12, 24, 120, 208 or 240
- End fittings available:
  - Full range of standard Parker end fittings
  - Robust "armored ends" with field replaceable stainless steel fittings
- Integrated thermocouple or RTD temperature monitor
- Nomex felt insulation **(2)**
- Continuous internal nylon braid kellow grip (foundation for strain reliefs) **(3)**
- Outer cover options:
  - High temperature silicone firesleeve
  - Corrugated polyamide 12 **(4)**
  - Nylon braid

### Heat Tube For Viscosity Control



Optional strain relief



Optional Polyamide 12 cover



Optional firesleeve cover



Optional controller

### Markets

- Manufacturing
- Hospitals
- Farming
- Food / Beverage

### Applications

- Water (freeze protection)
- Plastics
- Epoxy
- Glues
- Fiberglass

### Features

- Light weight
- Flexible
- High thermal efficiency
- Long life span
- Temperature indicator lights
- UV and chemical resistant outer cover

### Available Accessories

- Strain Relief at user defined locations
- High performance insulation
- Pass through power, control, or thermocouple wiring
- 15, 20 or 30 amp, 120v controllers available

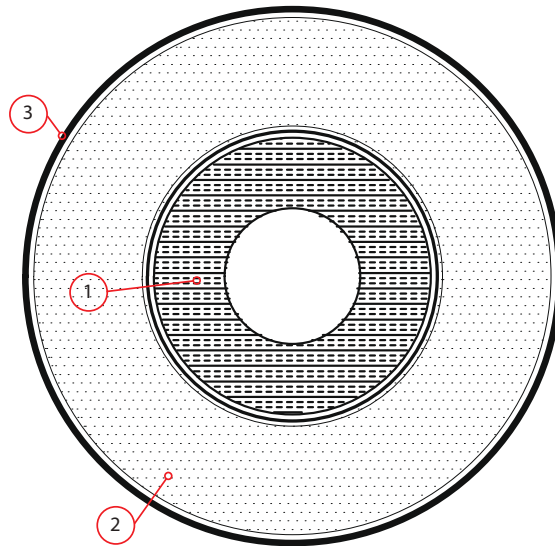

Standard Viscosity Control

- Parker 520N tubing of any size **(1)**
- Control options:
  - External control via integral thermocouple or RTD
  - Self-regulating to 175F
- Voltage options include 12, 24, 120, 208 or 240
- Full range of standard Parker end fittings
- Integrated thermocouple or RTD temperature monitor
- Nomex felt insulation **(2)**
- Continuous internal nylon braid kellum grip (foundation for strain reliefs)
- Outer cover options:
  - Nylon braid **(3)**
  - High temperature silicone firesleeve
  - Corrugated polyamide 12

### Size and Types of Tubing

- 1/8" to 1-3/4" OD machine wrapped to 100+ft. Length
- Nylon, Teflon, Aluminum, Stainless Steel, Copper
- Tubing can be customer supplied
- Multi-tube (up to 5 tubes in one bundle)

### Voltage

- AC and DC to 480 volts

### Insulations

- 1/4" Nomex standard
- Additional 1/4" increments for colder environments

### Electrical Terminations

- MILSPEC wire
- UL 3-prong plugs

### Heat Tube For Chemical Analysis

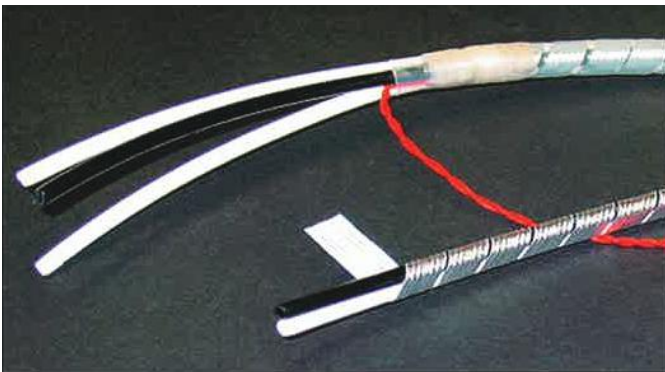

Twin tube multi-tube

### Wattage

- 1/8" to 1-3/4" OD machine wrapped to 100+ft. Length
- Nylon, Teflon, Aluminum, Stainless Steel, Copper
- Tubing can be customer supplied
- Multi-tube (up to 5 tubes in one bundle)

### Controls

- Embedded thermostat, thermocouple, RTDs
- End-to-end embedded TC and power wires

### Scuff Coating

- Clear heat shrink jacket
- Black braided jacket over insulation
- Silicone jacket in several colors

### End Configurations

- Polyvinyl heat shrink standard
- Copper armored for harsh environments
- Tube-in-tube
- Field removable stainless steel tube
- Strain relief

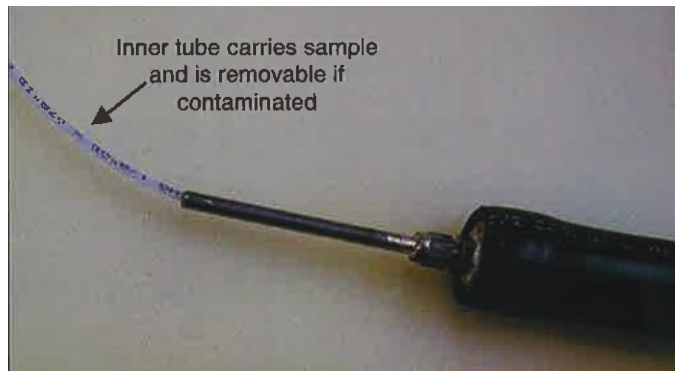

Removable tube in a Hot Tube



No.35, Jalan OP 1/2, Pusat Perdagangan One Puchong, Off Jalan Puchong, 47160 Puchong, Selangor Darul Ehsan, Malaysia.

+603-8071 6322

info@dpstar.com.my

+603-8071 6822

www.dpstar.com.my

